

Sintony System Migration

Sintony to SPC Migration

VANDERBILT

White Paper | August 2016

Over the last number of years Vanderbilt has worked faithfully to develop and bring to its customers the very best next generation intrusion system. We are proud to be able to present Vanderbilt SPC, an innovative and start-of-the-art intrusion system.

Vanderbilt acknowledges and appreciates its loyal customers and it is fundamental to Vanderbilt to maintain our dedicated customer base as we make the transition from the long standing Sintony product portfolio to the next generation SPC product portfolio.

Vanderbilt recognizes and understands the investment that will be necessary by our customers if they decide to move to SPC. Therefore, Vanderbilt is providing a potential migration path which we hope will help ease the investment burden.

The migration path provided by Vanderbilt will aid and support our transitioning customers but unfortunately it will not cover all eventualities. The purpose of this white paper is to describe Sintony System Migration.



Contents

The information contained in this document is to the best of knowledge, true and accurate. Whilst every effort has been made to ensure the accuracy, the document may be subject to errors or omissions.

Revision History	3
Migration Solution	4
SPC E-Bus Gateway	4
System Setup and Configuration	5
Migration Product Portfolio	6
What Sintony peripheral products are supported?	6
Excluded Sintony peripheral products	8
Wireless Sintony peripheral products	8
Which SPC control panel is recommended?	9
What Sintony System Size can be supported?	9
Migration Concepts	12
Physical Migration	12
Infrastructure Simulation	12
Peripheral Device Simulation	12
Peripheral Device Addressing	13
Functionality Support	22
Keypad functionality support	22
Zone functionality support	23
PSU functionality support	23
Migration Scenarios	26
Example 1: Small Installation	26
Example 2: Medium Installation	27
Example 3: Large Installation	30

Revision History

Rev	Date	Remarks
0.1	2013-12	Released
0.2	2016-8	Rebranded

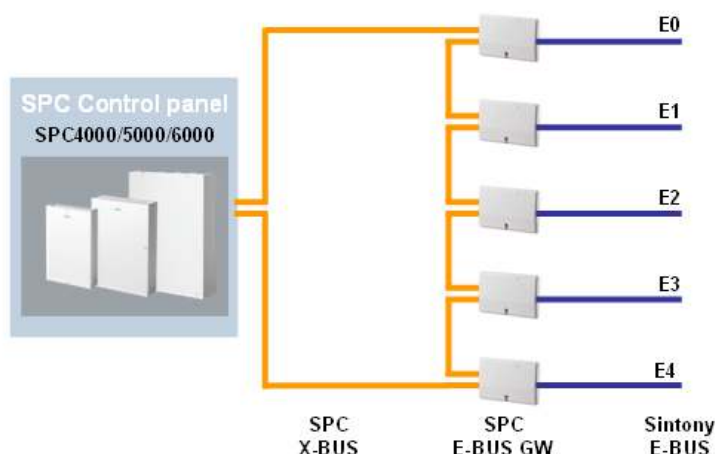

“This is achieved by installing an SPC E-Bus Gateway which allows newly installed SPC system panels communicate with the Sintony E-Bus network and its E-Bus devices.”

Migration Solution

If a customer decides to migrate from an existing Sintony installation to an SPC installation, it is not necessary to remove the Sintony installation in its entirety. Depending on the components of the Sintony installation many Sintony network device products can remain in place on the Sintony E-Bus. This is achieved by installing an SPC E-Bus Gateway which allows newly installed SPC system panels communicate with the Sintony E-Bus network and its E-Bus devices.

The SPC E-Bus Gateway facilitates:

- The conversion of Sintony E-Bus device information to information understood by the SPC system controller
- The conversion of SPC system controller information to information understood by Sintony devices

SPC E-Bus Gateway

The Vanderbilt SPC E-Bus Gateway is an SPC X-BUS device (PCB only):

- Material Description: SPCG310.000 / Material No.: S54554-A101-A100

It can be installed directly within the SPC control panel housing, the SAH14 (Sintony transponder) housing or in the external power supply housing. The SPC X-BUS is wired to the X-Bus terminals of the SPC E-Bus GW and the Sintony E-Bus is wired to the E-Bus terminals on the SPC E-Bus GW. The SPC E-Bus Gateway effectively translates messages between the SPC X-BUS and the Sintony E-Bus for the SPC controller.

For more detailed installation instructions please see SPC E-Bus Gateway Installation Guide.



System Setup and Configuration

Note: Prior to starting the migration process, review and document all existing Sintony peripheral device address IDs on all Sintony E-Bus sections

The first step in a Sintony to SPC migration is to perform the physical migration. This will always involve at the very minimum the physical replacement of a Sintony controller with a suitable SPC controller and the addition of at least one SPC E-Bus GW (SPCG310).

The SPC X-BUS is wired to the X-Bus terminals of the SPC E-Bus GW and the Sintony E-Bus is wired to the E-Bus terminals of the SPC E-Bus GW. The X-BUS address IDs of the SPC E-Bus GW(s) should be assigned at this point.

If the migration system contains more than one E-Bus section; before power up, ensure that power / communication is only available for one E-Bus section, E0. Ensure power / communication is not available on E-Bus sections E1...E4.

The idea behind only powering-up one E-Bus section at a time is to anticipate potential BUS address ID clashes and allow for the re-addressing of peripheral devices in advance (please see section: Peripheral Device Addressing).

1. Power-up the migration system, the panel is in its defaulted state.
2. Initialization of the migration system can be performed through either a Sintony SAK41/51/53 keypad or an SPC keypad. If initialization is carried out using a Sintony SAK41/51/53 keypad; the keypad menu which appears on the Sintony keypad is the SPC keypad menu.
3. Press a key on the keypad, choose your LANGUAGE, enter the DATE and TIME and choose the relevant REGION.
4. Choose a TYPE of installation:
 - DOMESTIC: is appropriate for home use (houses and apartments).
 - COMMERCIAL: provides additional zone types and commercial zone default descriptions.
 - FINANCIAL: is specific for banks and other financial institutions.
5. Choose the X-BUS addressing mode: MANUAL.

Note: For migration installations AUTO addressing is not supported.

6. Choose the installation topology: LOOP (Ring) or SPUR (Chain): the system scans for the quantity of keypads, expanders, door controllers and available zone inputs.

Note: Sintony to SPC migration does not support Star and Multi-drop cabling methods.

7. Press NEXT to scan all X-BUS devices and simulated X-BUS devices (or Sintony peripheral devices).
8. Program the Ethernet port and establish IP communication.

Note: For migration addressing of Sintony E-Bus devices (or simulated X-BUS devices) is only possible via the browser.

9. Access the SPC web browser and review all configured keypads, expanders and door controllers on the system.
10. All X-BUS address IDs should be noted and peripheral device addressing steps followed as necessary.

Note: Step 10 marks the end of the set-up procedure for migration of single E-Bus E0 Sintony systems.

11. Power down the E-Bus section E0 and power up the next E-Bus section e.g. E1.
12. Go to the SPC web browser page; Settings -> X-BUS -> Expanders and select reconfigure. All E-Bus E1 peripheral devices can be reviewed.
13. Where necessary re-assign address IDs so as to avoid any potential address ID clashes in other E-Bus sections.
14. Repeat steps 11 to 13 for any remaining E-Bus sections
15. Once happy that no duplicate IDs exist on the system, power-up the entire system and reconfigure for a final time.

Migration Product Portfolio

The most successful Sintony System Migration happens when an existing Sintony installation is migrated to SPC without having to remove any of the functioning Sintony E-Bus peripheral products. This scenario requires the removal of the Sintony control panel, replacing it with the SPC control panel and the installation of the SPC E-Bus Gateway.

What Sintony peripheral products are supported?

When determining to what extent an existing Sintony installation can benefit from the migration solution, one should understand which Sintony E-Bus peripheral products are supported.

Peripheral Product	Hardware Versions		Firmware Versions
SAT12/SMT12	Current Version	02-02	ZF0682 B1 / F944/Wk-Yr
	Previous Versions*	IC1, IC0, IB4, IB3, IB2, IB1, IA5	ZF0682 A8 / 2F03/Wk-Yr ZF0682 A8
SAT22/SMT22	Current Version	AS03/ES01	ZF0682 B1 / 7944/Wk-Yr
	Previous Version*	Rev01/BS01	
SAT24/SMT24	Current Version	AS02/ES01	ZF0682 B1 / 7944/Wk-Yr
	Previous Version*	Rev01/BS01	
SAT44/SMT44	Current Version	IB2	ZZ0890 A0 / 7385/Wk-Yr
	Previous Versions*	IB1, IA2	
SAK41/SMK41	Current Versions	IC2, IC1	ZZ0777 B1/ B565/Wk-Yr
	Previous Version*	IC0	ZZ0777 A3/Wk-Yr
SAK51/SMK51	Current Version	IE1	ZZ0777 B1 / B565/Wk-Yr
	Previous Versions*	ID1, IC0	ZZ0777 A3 /Wk-Yr
SAK53/SMK53	Current Version	IC1	ZZ0777 B1 / B565/Wk-Yr
	Previous Version*	IB0	ZZ0777 A3/Wk-Yr

Peripheral Product	Hardware Versions		Firmware Versions
SMR11	Current Version	IC1	NA
	Previous Versions*	IC0, IB3, IB2, IB1	
SAP08 (SMP08 SBT552231-Inactive)	Last Version	IC2	ZZ0727 B1 / 60E5/Wk-Yr
	Previous Version*	IC1	
SAP14 (SMP14 SBT560689LF)	Current Version	IB4	ZZ0727 B1 / 60E5/Wk-Yr
	Previous Versions*	IB3, IB2, IB1, IA4	
SAP14 NF (SMP14 SBT560689LF)	Current Version	IB4	ZZ0727 B1 / 60E5/Wk-Yr
SAP14 SCA (SMP14 SBT560689LF - Inactive)	Last Version	IB4	ZZ0727 B1 / 60E5/Wk-Yr
	Previous Versions*	IB3, IA3, IA2, IA1, IA0	
SAP20 (SMP20 SBT554747LF)	Current Version	IC4	ZZ0727 B1 / 60E5/Wk-Yr
	Previous Versions*	IC3, IB2, IB1, IB0	
SAP20 NF (SMP20 SBT554747LF)	Current Version	IC4	ZZ0727 B1 / 60E5/Wk-Yr
	Previous Versions*	IC3, IB2, IB1, IB0	
SAP20 SCA (Inactive)	Last Version	IB2	ZZ0727 B1 / 60E5/Wk-Yr
	Previous Versions*	IB1, IB0	
SAP25 (SMP25 SBTS24243-A3200-A1 LF)	Current Version	IE3	ZZ0710 A1 / 6FBE/Wk-Yr
	Previous Versions*	IE2, ID5, ID4, ID3, ID2	

* By design, previous Sintony product versions are suitable for migration. However, they have not been individually tested and therefore their operation for migration cannot be guaranteed.

Excluded Sintony peripheral products

In principal, Sintony peripheral devices not included in the above section “What Sintony peripheral products are supported?” can be assumed to be excluded.

Some important exclusions are listed in the following table:

Keypads	SAK52	LCD Keypad with audio
	SAK84	LCD Keypad with audio expander
	SAK94	Multi-partition keypad with audio expander
Simple-UI	SAK9S1	Universal key switch module (1 key switch, 2 LED's)
	SAK9L1	Universal indication/key module (4 keys, 16 LED's)
Multimedia	WAC12	Loudspeaker/Microphone (addressable)
	WAT21	Video/Audio transponder
Gateways	SMG71	Card reader gateway board
	SAG91	Sintony E-Bus Gateway (must be replaced with SPC E-Bus Gateway)
	SMG81	Sintony LSN(i) gateway
	Wireless	Si(2)way, Siroute, Label

Wireless Sintony peripheral products

Sintony Label and SiRoute wireless devices are not supported for migration.

SPC does support a range of SiWay wireless devices and therefore should a Sintony system have existing SiWay wireless devices then following migration these can be supported.

The range of SiWay wireless supported devices are listed in the following table:

IR160W6-10	PIR detector 18 m, black triplex mirror
IR65W6-10	PIR detector, ceiling mount
ADM-I12W1	PIR wireless 868 MHz detector
IGBW6-10	Glass break detector
IOPW6-11	Smoke detector
IMKW6-10	Magnet contact
IWFW6-10	Flood detectors
IRCW6-11	Remote control
IKPW6-10	Wireless LED keypad
IPAW8-10	Wireless Personal Alarm

Which SPC control panel is recommended?

When determining which SPC controller to install, please refer to the following recommendations:

Sintony Controller	Recommended SPC Controller
SI1xx	SPC4xxx
SI2xx	SPC5xxx
SI32x	SPC5xxx
SI34x	SPC6xxx
SI41x	SPC6xxx
SI42x	SPC6xxx

What Sintony System Size can be supported?

The following tables outline the maximum number of Sintony E-Bus peripheral products which are supported by the SPC controller.

SAT12/22/24, SMT12/22/24 Supported in Sintony		SAT12/22/24, SMT12/22/24 Supported in SPC	
Sintony Controller	Max. Number SAT12/22/24, SMT12/22/24	SPC Controller	Max. Number SAT12/22/24, SMT12/22/24
SI1xx	4	SPC4xxx	4
SI2xx	10	SPC5xxx	15
SI32x	8	SPC5xxx	15
SI34x	34	SPC6xxx	63
SI41x	112	SPC6xxx	63
SI42x	110	SPC6xxx	63

SAT44, SMT44 Supported in Sintony		SAT44, SMT44 Supported in SPC	
Sintony Controller	Max. Number SAT44, SMT44	SPC Controller	Max. No. SAT44, SMT44
SI1xx	1	SPC4xxx	4
SI2xx	2	SPC5xxx	4
SI32x	2	SPC5xxx	4
SI34x	3	SPC6xxx	4
SI41x	3	SPC6xxx	4
SI42x	3	SPC6xxx	4

SAK41/51/53, SMK41/51/53 Supported in Sintony		SAK41/51/53, SMK41/51/53 Supported in SPC	
Sintony Controller	Max. Number SAK41/51/53, SMK41/51/53	SPC Controller	Max. Number SAK41/51/53, SMK41/51/53
SI1xx	3	SPC4xxx	4
SI2xx	7	SPC5xxx	16
SI32x	7	SPC5xxx	16
SI34x	16	SPC6xxx	16
SI41x	32	SPC6xxx	16
SI42x	32	SPC6xxx	16

SAP08/14/20/25, SMP08/14/20/25 Supported in Sintony (E-Bus PSUs only, excl. controller)		SAP08/14/20/25, SMP08/14/20/25 Supported in SPC	
Sintony Controller	Max. Number SAP08/14/20/25, SMP08/14/20/25	SPC Controller	Max. Number SAP08/14/20/25, SMP08/14/20/25
SI1xx	2 [SAP14/20, SMP14/20]	SPC4xxx	5
SI2xx	5 [SAP14/20, SMP14/20]	SPC5xxx	16
SI32x	5 [SAP08/25, SMP08/25]	SPC5xxx	16
SI34x	7 [SAP25, SMP25]	SPC6xxx	16
SI41x	15 [SAP14/20, SMP14/20]	SPC6xxx	16
SI42x	15 [SAP25, SMP25]	SPC6xxx	16

Note: Sintony power supplies have been specifically designed to support Sintony peripheral devices. For migration it is recommended that existing Sintony power supplies remain in situ as far as possible.

The following tables outline the maximum number of Sintony input and output zones which are supported by the SPC controller.

Input zones: Supported in Sintony		Input zones: Supported in SPC	
Sintony Controller	Max. Number Inputs (excl. controller inputs)	SPC Controller	Max. Number Inputs (excl. controller inputs)
SI1xx	16	SPC4xxx	16
SI2xx	40	SPC5xxx	60
SI32x	32	SPC5xxx	60
SI34x	136	SPC6xxx	252
SI41x	448	SPC6xxx	252
SI42x	440	SPC6xxx	252

Output zones: Supported in Sintony		Output zones: Supported in SPC	
Sintony Controller	Max. Number Outputs (excl. controller outputs)	SPC Controller	Max. Number Outputs (excl. controller outputs)
SI1xx	18	SPC4xxx	40
SI2xx	41	SPC5xxx	62
SI32x	36	SPC5xxx	78
SI34x	59	SPC6xxx	174
SI41x	143	SPC6xxx	158
SI42x	139	SPC6xxx	174

Migration Concepts

Physical Migration

To perform the physical migration, the existing Sintony control panel is removed and replaced with a new SPC control panel. The Sintony E-Bus is disconnected when the Sintony control panel is removed. A new SPC E-Bus GW is added to the system. The SPC controller is wired to the X-Bus terminals of the newly added SPC E-Bus GW (as per normal SPC X-Bus peripheral devices) and the previously disconnected E-Bus is re-wired to the E-Bus terminals of the SPC E-Bus GW.

Where a Sintony system has additional E-Bus extension sections (E1...E4) connected to the E0 Bus via SAG91 E-Bus expander gateways, the SAG91 E-Bus expander gateways must be removed and replaced with SPCG310 E-Bus expander gateways. The Sintony E-Bus extension sections must be re-wired via the SPCG310 E-Bus expander gateways to connect them to the SPC X-BUS.

For more detailed wiring information please refer to SPC E-Bus GW installation instructions.

Infrastructure Simulation

The job of the SPC E-Bus GW is to make the E-Bus network take on the appearance of an SPC X-BUS network. In doing this Sintony E-Bus peripheral devices on the Sintony E-Bus network now appear to the SPC controller as SPC X-Bus devices on the SPC X-BUS network.

An existing Sintony system BUS with one or more E-Bus sections (E0...E4) is mapped to a single simulated SPC X-BUS.

Peripheral Device Simulation

The SPC E-Bus GW (SPCG310) enables the SPC Controller to see Sintony peripheral devices as SPC peripheral devices. This is done by mapping similar Sintony peripheral devices to SPC peripheral devices. The SPC E-Bus GW (SPCG310) performs the following simulations:

Sintony Peripheral Devices	Simulated Sintony Peripheral Devices (as presented to SPC Controller)	
SAT12/SMT12	SPCE652	I/O [8 Input / 2 Output]
SAT22/SMT22		
SAT24/SMT24		
SAT44/SMT44	SPCE452	I/O [8 Output]
SAK41/SMK41	SPCK420	Keypad
SAK51/SMK51		
SAK53/SMK53		
SMR11	-	-
SAP08* (+ SMT12)	SPCP355 + SPCE652	Power Supply + I/O [8 Input / 2 Output]
SAP14 * (+ SMT12)	SPCP355 + SPCE652	Power Supply + I/O [8 Input / 2 Output]
SAP20* (+ SMT12)	SPCP355 + SPCE652	Power Supply +I/O [8 Input / 2 Output]
SAP25 (+ 8 inputs)	SPCP355 + 2 X SPCE652	Power Supply +2 X I/O [8 Input / 2 Output]

* If an associated SMT12 does not already exist for SAP08/14/20 then for migration an additional SMT12 must be added to the system.

Peripheral Device Addressing

The SPC controller locates peripheral devices on the X-BUS by using their unique address ID. Therefore, each peripheral device must have a unique address ID.

Note: Sintony allows duplicate peripheral device IDs on its system, SPC does not.

Sintony allows duplicate peripheral device IDs on different E-Bus sections e.g. an I/O transponder can be allocated ID1 on E0 and another I/O transponder can also be allocated ID1 on E1. SPC does not allow duplicate peripheral device IDs, each peripheral device on a SPC system must have a unique address ID.

It is very important to make sure during migration of the installation from Sintony to SPC no duplicate peripheral device ID exists on the system.

Note: Prior to starting the migration process review and document all existing Sintony peripheral device address IDs on all Sintony E-Bus sections

The following peripheral device addressing steps are recommended:

1. Assign SPC E-Bus GW address IDs
2. Accept / Re-assign Power Supply address IDs
3. Accept / Re-assign Input/Output transponder address IDs
4. Re-assign Output transponder address IDs
5. Re-assign Keypad address IDs

Assign SPC E-Bus GW address IDs

The maximum number of SPC E-Bus GW (SPCG310) supported on a Sintony to SPC migration system is five, one SPC E-Bus GW per Sintony E-Bus. The SPC E-Bus GW is an SPC expander device and as such can be addressed with an X-BUS ID in the range ID1...ID99. However, it is recommended (to avoid potential X-BUS address ID clashes caused by duplicate address IDs) that the SPC E-Bus GW (SPCG310) be addressed in the range ID95...ID99, starting with ID99.

Device	Addressing	
	Sintony Bus	X-BUS ID
SPCG310	E0	99
	E1	98
	E2	97
	E3	96
	E4	95

Note: When assigning SPC E-Bus GW address IDs cross check against existing Sintony peripheral device address IDs for potential ID duplicates.

As well as each SPC E-Bus GW having a unique address ID, the SPC E-Bus GW will also have a virtual serial number (S/N) associated with it, ending in "00". The purpose of the virtual serial number is to help identify the Sintony peripheral devices which are migrated by each SPC E-Bus GW.

Each Sintony peripheral device migrated by a SPC E-Bus GW will also have a virtual serial number (S/N). This virtual number will be made up of the associated SPC E-Bus GW and the peripheral device address ID.

Alarms disabled full engineer mode

Keypads | Expanders | Door Controllers | Cable Map | Settings

X-BUS Cable Map

Position	ID	Status	Type	S/N	Description
1	5	Active	I/O [8 Output]	102190801	IO 5
2	98	Active	Gateway	5020700	GW98
3	81	Active	Keypad	5020781	KEY 81
4	71	Active	I/O [8 Output]	5020771	IO 71
5	72	Active	I/O [8 Output]	5020772	IO 72
6	82	Active	Keypad	5020782	KEY 82
7	19	Active	I/O [8 Input / 2 Output]	5020719	IO 19
8	1	Active	I/O [8 Input / 2 Output]	5020701	IO 1
9	2	Active	I/O [8 Input / 2 Output]	5020702	IO 2
10	3	Active	I/O [8 Input / 2 Output]	5020703	IO 3
11	4	Active	I/O [8 Input / 2 Output]	102117801	IO 4
12	3	Active	Keypad	105862801	KEY 3

Reconfigure

Accept / Re-assign Power Supply address IDs

SPC power supply units (PSU) are always installed with accompanying I/O expanders. These accompanying I/O expanders have unique address IDs and are associated with the installed SPC PSU. The SPC controller identifies SPC power supply units on the X-BUS via the unique address ID of the associated I/O expanders.

Sintony SAP08/14/20/25 power supplies, which have E-Bus IDs, are mapped to simulated SPC SPCP355 power supplies, which do not have X-BUS IDs. In order for SAP08/14/20/25 power supplies to be identified on the simulated SPC X-BUS there must be a mapping of associated Sintony PSU transponders to simulated SPC PSU expanders.

Note: If a Sintony PSU does not have an associated I/O transponder in situ then an I/O transponder must be added to the Sintony system in order to support PSU identification.

Note: Sintony power supplies have been specifically designed to support Sintony peripheral devices. For migration it is recommended that existing Sintony power supplies remain in situ as far as possible.

For migration, a SPC system can support up to 16 Sintony power supplies. However, the X-BUS address range of the simulated PSU associated I/O expanders must be within ID1...ID31.

In Sintony installations transponders associated with SAP08/14/20/25 must acquire the following address ID format:

- $2N - 1$ (where N = Address ID of PSU)

If the address IDs of the Sintony SAP08/14/20/25 power supplies on the Sintony E-Bus are within the range ID1...ID16, making their associated I/O transponder address IDs within the range ID1...ID32, then the associated I/O transponder address IDs can be directly mapped to X-BUS IDs and accepted by the SPC controller.

E-Bus Address ID		X-BUS Address ID	
SAP08/14/20/25	PSU associated I/O Transponder	Simulated SPCP355	Simulated PSU associated I/O Expander
1	1	-	1
2	3	-	3
3	5	-	5
4	7	-	7
5	9	-	9
6	11	-	11
7	13	-	13
8	15	-	15
9	17	-	17
10	19	-	19
11	21	-	21
12	23	-	23
13	25	-	25
14	27	-	27
15	29	-	29
16	31	-	31

Note: The SAP25 has 2 associated I/O transponders, the addresses of which are 2N-1 and 2N; N = Address ID of PSU. Only the I/O transponder with address 2N-1 is shown to have an associated PSU. I/O transponder with address 2N is shown as a standard X-Bus expander.

There are some scenarios where the PSU associated I/O transponders address IDs cannot be directly mapped and accepted by the SPC controller:

- If a Sintony PSU ID and its associated I/O transponder ID on the E-Bus is outside the supported ranges i.e. greater than ID16 and ID32 respectively
- If the Sintony PSU ID and its associated I/O transponder ID on the E-Bus is a duplicate address ID i.e. I/O transponder ID1 exists on both E0 and E1

In these cases, the PSU associated I/O transponder address needs to be re-assigned so that it can be recognized the SPC controller.

In order to re-assign a PSU associated I/O transponder address ID go to the following page on the SPC web browser; Settings -> X-BUS -> Expanders and select the SPC E-Bus GW Expander that supports the PSU which needs to have its address ID re-assigned.

In the following example SPC E-Bus GW 10 supports a Sintony PSU which needs to have its address ID re-assigned. Select the drop down box for "Select E-Bus id (X-Bus expander ID): PSU". Available E-Bus PSU IDs and their

associated I/O transponder IDs (or simulated X-Bus I/O expander IDs) are shown. Select a new PSU address ID, save and then reconfigure. The new address is broadcast to the device. The new address on the Sintony E-Bus device is programmed by pressing the device's addressing key.

Alarms disabled full engineer mode

Status | System | Controller | **X-BUS** | Comms. | Verification | Advanced | Test Menu

Keypads | Expanders | Door Controllers | Cable Map | Settings

Expander Configuration

Expander ID: 10
Type: SPC E-Bus Gateway
S/N: 5022100
Description: GW 10

Select E-BUS id (X-Bus expander ID): Keypad: None [v] [Select]
Select E-BUS id (X-Bus expander ID): Input: None [v] [Select]
Select E-BUS id (X-Bus expander ID): Output: None [v] [Select]
Select E-BUS id (X-Bus expander ID): PSU: None [v] [Select]

Note
* Address in use
Addressing an SMT25 will cause a conflict
! Addressed expander available for PSU assignment

[Save] [Back] [Cancel]

The I/O transponder (or simulated X-Bus I/O expander) and its newly assigned address ID will be immediately displayed in the SPC “Configured Expanders” list with its associated PSU.

⚠ ⚠ ⚠ ⚠ ⚠
⚠ ⚠ ⚠ ⚠ ⚠
Alarms disabled full engineer mode

Status	System	Controller	X-BUS	Comms.	Verification	Advanced	Test Menu
Keypads Expanders Door Controllers Cable Map Settings							

Configured Expanders

ID	Description	Status	Type	S/N	Version	Reader	Wireless	PSU
2	KSW 12	Online	Keypad [1 Output]	1000801073	1.01 [11NOV10]	Not Fitted	Not Fitted	Not Fitted
3	IND 11	Online	Indicator [1 Input]	1000801016	1.03 [13MAR13]	EM4100	Not Fitted	Not Fitted
4	IOA 7	Online	I/O Analyzed [8 Input / 2 Output]	165082801	1.12 [13MAR13]	Not Fitted	Not Fitted	Not Fitted
5	IO 2	Online	I/O [8 Input / 2 Output]	94262801	1.11 [07AUG13]	Not Fitted	Not Fitted	Type 1 - V4
6	IO 13	Online	I/O [8 Input / 2 Output]	94264801	1.11 [07AUG13]	Not Fitted	Not Fitted	Not Fitted
7	AEX 1	Online	Audio [4 Input]	15474907	1.03 [13MAR13]	Not Fitted	Not Fitted	Not Fitted
8	IO 6	Online	I/O [8 Input / 2 Output]	4364551	1.11 [07AUG13]	Not Fitted	Not Fitted	Not Fitted
10	GW 10	Online	SPC E-Bus Gateway	5022100	1.00 [Build14]	Not Fitted	Not Fitted	Not Fitted
11	IO 11	Online	I/O [8 Input / 2 Output]	5022111	0.00 [EBUS-IO]	Not Fitted	Not Fitted	Type 2 - V0
15	IO 15	Online	I/O [8 Input / 2 Output]	5022115	0.00 [EBUS-IO]	Not Fitted	Not Fitted	Not Fitted
20	GW 12	Online	SPC E-Bus Gateway	5021400	1.00 [Build14]	Not Fitted	Not Fitted	Not Fitted
21	IO 8	Online	I/O [8 Input / 2 Output]	5021421	0.00 [EBUS-IO]	Not Fitted	Not Fitted	Not Fitted
22	IO 9	Online	I/O [8 Input / 2 Output]	5021422	0.00 [EBUS-IO]	Not Fitted	Not Fitted	Not Fitted
71	IO 71	Online	I/O [8 Output]	5022171	0.00 [EBUS-O]	Not Fitted	Not Fitted	Not Fitted
72	IO 10	Online	I/O [8 Output]	5021472	0.00 [EBUS-O]	Not Fitted	Not Fitted	Not Fitted

©2013, Siemens AB - Security Products

Note: In the case of the Sintony PSU SAP25, two new transponders (or simulated X-Bus I/O expanders) are immediately displayed in the configured expanders list; however it takes approximately 2 minutes for the associated PSU to be displayed.

Accept / Re-assign Input/Output transponder address IDs

Sintony SAT12/22/24 I/O transponders which have E-Bus address IDs are mapped to simulated SPC SPCE652 I/O expanders with X-BUS address IDs.

A SPC4xxx controller can support up to 4 Sintony SAT12/22/24 I/O transponders. If the address IDs of the Sintony SAT12/22/24 I/O transponders on the Sintony E-Bus are within the range ID1...ID4, then the I/O transponders can be directly mapped to X-BUS IDs and accepted by the SPC4xxx controller.

A SPC5xxx controller can support up to 15 Sintony SAT12/22/24 I/O transponders. If the address IDs of the Sintony SAT12/22/24 I/O transponders on the Sintony E-Bus are within the range ID1...ID15, then the I/O transponders can be directly mapped to X-BUS IDs and accepted by the SPC5xxx controller.

A SPC6xxx controller can support up to 63 Sintony SAT12/22/24 I/O transponders. If the address IDs of the Sintony SAT12/22/24 I/O transponders on the Sintony E-Bus are within the range ID1...ID63, then the I/O transponders can be directly mapped to X-BUS IDs and accepted by the SPC6xxx controller.

SAT12/22/24 I/O Transponder	Simulated SPCE652 I/O Expander		
E-Bus Address ID	X-BUS Address ID (SPC4xxx)	X-BUS Address ID (SPC5xxx)	X-BUS Address ID (SPC6xxx)
1	1	1	1
2	2	2	2
3	3	3	3
4	4	4	4
5	-	5	5
6	-	6	6
7	-	7	7
8	-	8	8
9	-	9	9
10	-	10	10
11	-	11	11
12	-	12	12
13	-	13	13
14	-	14	14
15	-	15	15
16	-	-	16
17	-	-	17
18	-	-	18
...
63	-	-	63

There are some scenarios where the SAT12/22/24 I/O transponders address IDs cannot be directly mapped and accepted by the SPC controller:

- If a Sintony SAT12/22/24 I/O transponders address ID on the E-Bus is outside the supported range for a particular SPC controller e.g. in the case of the SPC4xxx system, if an I/O transponder address ID is greater than ID4
- If the Sintony SAT12/22/24 I/O transponders address ID on the E-Bus is a duplicate address ID e.g. I/O transponder ID1 exists on both E0 and E1
- If a Sintony SAT12/22/24 I/O transponder has an address ID on the E-Bus which has been previously assigned to a PSU associated I/O transponder

Duplicate IDs will appear as an error.

Invalid or duplicate ID for Expander ID 71

X-BUS Cable Map

Position	ID	Status	Type	S/N	Description
1	2	Active	I/O [8 Output]	102190801	IO 2
2	98	Active	Gateway	5020700	GW 98
3	82	Active	Keypad	5021782	KEY 82
4	21	Active	I/O [8 Input / 2 Output]	5020721	IO 21
5	71	Active	I/O [8 Output]	5020771	IO 71
6	22	Active	I/O [8 Input / 2 Output]	5020722	IO 22
7	13	Active	I/O [8 Input / 2 Output]	5020713	IO 13
8	14	Active	I/O [8 Input / 2 Output]	5020714	IO 14
9	99	Active	Gateway	5021500	GW99
10	81	Active	Keypad	5021581	KEY 81
11	19	Active	I/O [8 Input / 2 Output]	5021519	IO 19
12	20	Active	I/O [8 Input / 2 Output]	5021520	IO 20
13	71	Active	I/O [8 Output]	5021571	IO 71
14	29	Active	I/O [8 Input / 2 Output]	5021529	IO 29
15	4	Active	I/O [8 Input / 2 Output]	102117801	IO 1

Reconfigure

Note: Only duplicate IDs which exist on different SPC E-Bus GWs (e.g. Output transponder ID71 exists on GW ID98 and ID71 exists on GW ID 99) are flagged as an error.

Duplicate IDs which exist on the same SPC E-Bus GW are not flagged as an error. Two transponders with the same ID on a single GW will appear as one single device, resulting in one of the two transponders not being identified by SPC.

In these cases, the I/O transponder address ID needs to be re-assigned so that it can be recognized the SPC controller.

In order to re-assign an I/O transponder address ID go to the following page on the SPC web browser; Settings -> X-BUS -> Expanders and select the SPC E-Bus GW Expander that supports the I/O transponder which needs to have its address ID re-assigned.

This time select the drop down box for "Select E-Bus id (X-Bus expander ID): Input". Available E-Bus I/O transponder IDs and their available simulated X-Bus I/O expander IDs are shown. Select a new address ID, save and then reconfigure. The new address is broadcast to the device. The new address on the Sintony E-Bus device is programmed by pressing the device's addressing key.

The I/O transponder (or simulated X-Bus I/O expander) and its newly assigned address ID will be immediately displayed in the SPC "Configured Expanders" list.

Re-assign Output transponder address IDs

Sintony SAT/SMT44 Output transponders which have E-Bus address IDs are mapped to simulated SPC SPCE452 Output expanders with X-BUS address IDs.

All SPC controllers can support up to 4 Sintony SAT/SMT44 Output transponders. The SAT/SMT44 Output transponders must have address IDs within the range ID71...ID73 to be recognized by the SPC controller.

SAT/SMT44 I/O Transponder	Simulated SPCE452 I/O Expander
E-Bus Address ID	Available X-BUS Address IDs
1	71
2	72
3	73
4	74

In order to re-assign an Output transponder address ID go to the following page on the SPC web browser; Settings -> X-BUS -> Expanders and select the SPC E-Bus GW Expander that supports the Output transponder which needs to have its address ID re-assigned.

This time select the drop down box for "Select E-Bus id (X-Bus expander ID): Output". Available E-Bus Output transponder IDs and their available simulated X-Bus I/O expander IDs are shown. Select a new address ID, save and then reconfigure. The new address is broadcast to the device. The new address on the Sintony E-Bus device is programmed by pressing the device's addressing key.

The Output transponder (or simulated X-Bus I/O expander) and its newly assigned address ID will be immediately displayed in the SPC "Configured Expanders" list.

Re-assign Keypad address IDs

Sintony SAK41/51/53 keypads which have E-Bus address IDs are mapped to simulated SPC SPCK420 keypads with X-BUS address IDs.

A SPC4xxx controller can support up to 4 Sintony SAK41/51/53 keypads.

A SPC5xxx and SPC6xxx controller can support up to 16 Sintony SAK41/51/53 keypads.

The SAK41/51/53 keypads must have address IDs within the range ID81...ID96 to be recognized by the SPC controller.

SAK41/51/53 Keypads	Simulated SPCK420 Keypads
E-Bus Address ID	Available X-BUS Address IDs
1	81
2	82
3	83
4	84
5	85
6	86
...	...
16	96

In order to re-assign an keypad address ID go to the following page on the SPC web browser; Settings -> X-BUS -> Expanders and select the SPC E-Bus GW Expander that supports the keypad which needs to have its address ID re-assigned.

This time select the drop down box for "Select E-Bus id (X-Bus expander ID): Keypad". Available E-Bus Keypad IDs and their available simulated X-Bus I/O expander IDs are shown. Select a new address ID, save and then reconfigure. The new address is broadcast to the device.

The E-Bus keypad (or simulated X-Bus keypad) and its newly assigned address ID will be immediately displayed in the SPC "Configured Keypads" list.

Functionality Support

As detailed Sintony peripheral devices are mapped to similar simulated SPC peripheral devices on the SPC controller. In most instances the equivalent device functionality is also mapped. However, there are some instances where functional limitations apply.

Keypad functionality support

User functionality in the SAK41, SAK51 and SAK53 is supported for Sintony to SPC migration. This includes:

- Setting / Unsetting
- Handling alerts
- Fault indications
- Etc.

However, configuration functionality in the SAK41, SAK51 and SAK53 is not supported. This includes:

- Adding new Users
- Adding Areas
- Edit mode e.g. editing existing Users, Areas, Zones, etc.
- Peripheral device addressing
- Keypad LEDs: Alarm, User Logged-in & Question mark are not supported

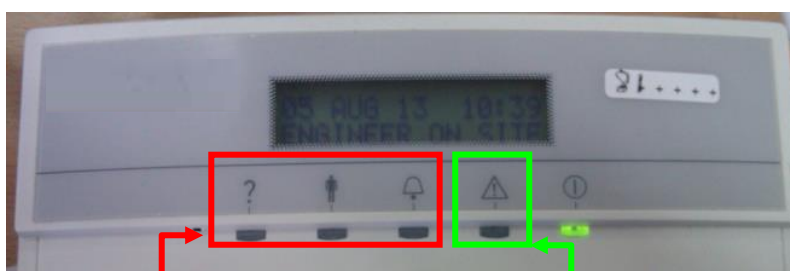

Not supported: LEDs are not activated e.g. an Alarm will not cause the red LED below the "Bell" symbol to activate.

Supported: An alert or an alarm will cause the orange LED below the "warning" symbol to activate.

Note: For migration, alarm indication on the Sintony keypad is now announced by the flashing of an orange LED below the "warning" symbol.

Note: If there is an attempt to access "Add/Edit" functionality within the SAK41, SAK51 and SAK53 keypads, a buzzer will sound to indicate that this functionality is not supported.

Buzzer Support	
Exit / Entry (with E/E zone closed)	Buzzer turns on
Exit / Entry (with E/E zone open)	Buzzer sounds 2 beeps per second
Alert present on system	Buzzer sounds 2 beeps per second
All other scenarios	Buzzer sounds 2 beeps per second

Zone functionality support

“Normally Open” zone functionality on Sintony I/O transponders is not mapped to SPC I/O expanders and therefore is not supported for migration.

PSU functionality support

When viewing the PSU status i.e. Sintony SAP08/14/20/25 power supplies simulated as SPC SPCP355 power supplies, it is important to understand that not all parameters are active.

PSU Status

Type: Vds PSU
 Version: Hardware Version: 0
 Firmware Version: 0.0 [EBUSPSU]

Mains status: **Ok**

Temperature	0 °C
Load Voltage	0.0 V
Load current	0 mA

* Charge status: **Fully charged**

Primary Circuit	Ok
Charge Circuit	Ok

Battery

		Voltage	Current
Battery 1	Ok	0.0V	0mA
Battery 2	Ok	0.0V	0mA

Outputs

	Voltage	Fuse	Tamper
** PSU Output 1	Ok	-Fuse Ok	
PSU Output 2	Ok	-Fuse Ok	
PSU Output 3	Ok	-Fuse Ok	
PSU Output 4	Ok	-Fuse Ok	
PSU Output 5	Ok	-Fuse Ok	
PSU Output 6	Ok	-Fuse Ok	Ok
PSU Output 7	Ok	-Fuse Ok	Ok
PSU Output 8	Ok	-Fuse Ok	Ok
NF Output	Ok	-Fuse Ok	
PSU Output 9	Ok	-Fuse Ok	

Refresh Back

Legend:

- Inactive parameters
- * Indication of Battery status only
- ** If fuse faults exist on any of the simulated Sintony PSUs, they are reported under “PSU Output 1”

Similarly, not all parameters of the Sintony power supplies and their associated I/O transponders are configurable. For the SAP08/14/20 the following limitations apply.

Alarms disabled full engineer mode

Status | System | Controller | X-BUS | Comms. | Verification | Advanced | Test Menu

Keypads | Expanders | Door Controllers | Cable Map | Settings

Expander Configuration

Expander ID: 19
 Type: I/O [8 Input / 2 Output]
 S/N: 5020719
 Description:

Input	End of Line	Zone	Description	Type	Area	Attributes
1	Dual 4K7 / 4K7	153	ZONE 153	Alarm	1: Area 1	...
2	Dual 4K7 / 4K7	154	ZONE 154	Alarm	1: Area 1	...
3	Dual 4K7 / 4K7	155	ZONE 155	Alarm	1: Area 1	...
4	Dual 4K7 / 4K7	156	ZONE 156	Alarm	1: Area 1	...
5	Dual 4K7 / 4K7	157		Unused	1: Area 1	...
6	Dual 4K7 / 4K7	158		Unused	1: Area 1	...
7	Dual 4K7 / 4K7	159		Unused	1: Area 1	...
8	Dual 4K7 / 4K7	160		Unused	1: Area 1	...

Output	Description	Type	Change type	Attributes	Test
1	<input type="text"/>	Disabled
* 2	<input type="text"/>	Disabled

PSU

Output	Description	Type	Change type	Attributes	TEST
1 (PCB 6)	<input type="text"/>	Disabled
2 (PCB 7)	<input type="text"/>	Disabled
3 (PCB 8)	<input type="text"/>	Disabled
4 (PCB 9)	<input type="text"/>	Disabled

Output monitor 6 Select if output should be monitored

Output monitor 7 Select if output should be monitored

Output monitor 8 Select if output should be monitored

Primary Battery only No second Battery on PSU

Save
Back

Inactive parameters

* The 2nd Output works in parallel with the Relay Output.

For the SAP25 the following limitations apply.

Expander Configuration

Expander ID: 19
 Type: I/O [8 Input / 2 Output]
 S/N: 5020719
 Description: IO 19

Input	End of Line	Zone	Description	Type	Area	Attributes
1	Dual 4K7 / 4K7	153	ZONE 153	Alarm	1: Area 1	...
2	Dual 4K7 / 4K7	154	ZONE 154	Alarm	1: Area 1	...
3	Dual 4K7 / 4K7	155	ZONE 155	Alarm	1: Area 1	...
4	Dual 4K7 / 4K7	156	ZONE 156	Alarm	1: Area 1	...
5	Dual 4K7 / 4K7	157		Unused	1: Area 1	...
6	Dual 4K7 / 4K7	158		Unused	1: Area 1	...
7	Dual 4K7 / 4K7	159		Unused	1: Area 1	...
8	Dual 4K7 / 4K7	160		Unused	1: Area 1	...

Output	Description	Type	Change type	Attributes	Test
1		Disabled
* 2		Disabled

PSU

Output	Description	Type	Change type	Attributes	TEST
1 (PCB 6)		Disabled
2 (PCB 7)		Disabled
3 (PCB 8)		Disabled
4 (PCB 9)		Disabled

Output monitor 6 Select if output should be monitored
 Output monitor 7 Select if output should be monitored
 Output monitor 8 Select if output should be monitored

Primary Battery only No second Battery on PSU

Save Back

Physical output designation on Sintony SMP25 PSU

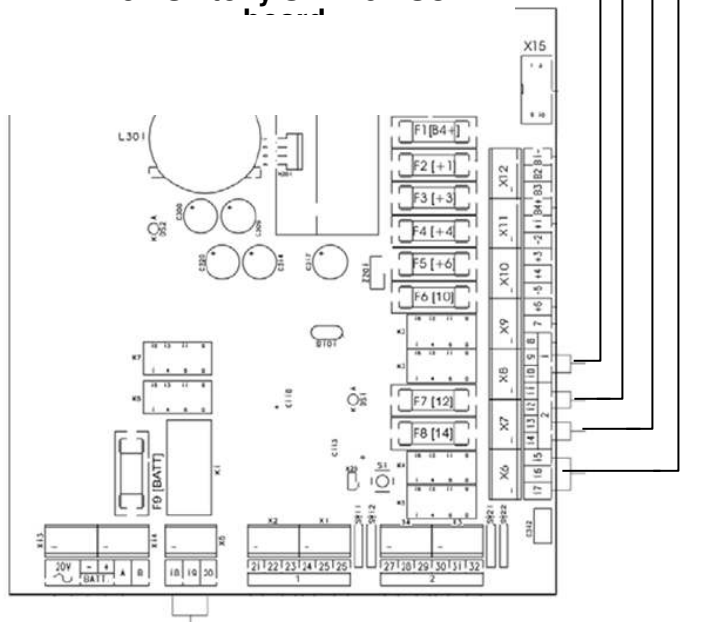

Output 1, Output 2 and Output 3 are supervised relay outputs. Output 4 is an Open Collector output.

 Inactive parameters

* The 2nd Output works in parallel with the Relay Output.

Migration Scenarios

Example 1: Small Installation

The following is an example of a small Sintony installation, consisting of:

- 1 X SI120 Sintony Control Panel
- 1 X E-Bus (E0)
- 4 X SAT12; 1 X SAT44; 1 X SAK51

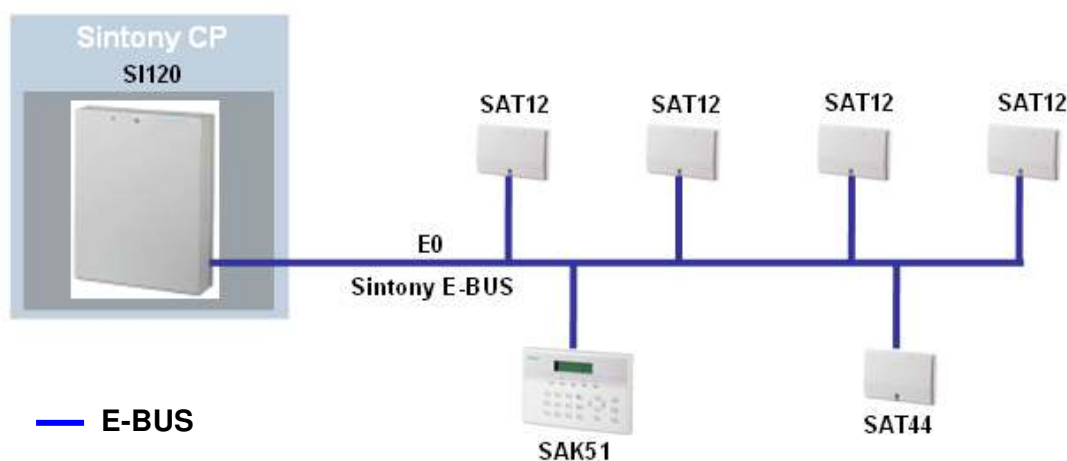

Physical Migration

The existing Sintony CP SI120 is replaced with a new SPC4xxx control panel. The Sintony E-Bus (E0) is disconnected when the SI120 control panel is removed. A new SPC E-Bus GW (SPCG310) is added to the system. The Sintony E-Bus (E0) is re-wired to the E-Bus terminals of the newly added SPC E-Bus GW and the SPC X-BUS is wired to the X-Bus terminals of the SPC E-Bus GW (as per normal SPC X-Bus peripheral devices).

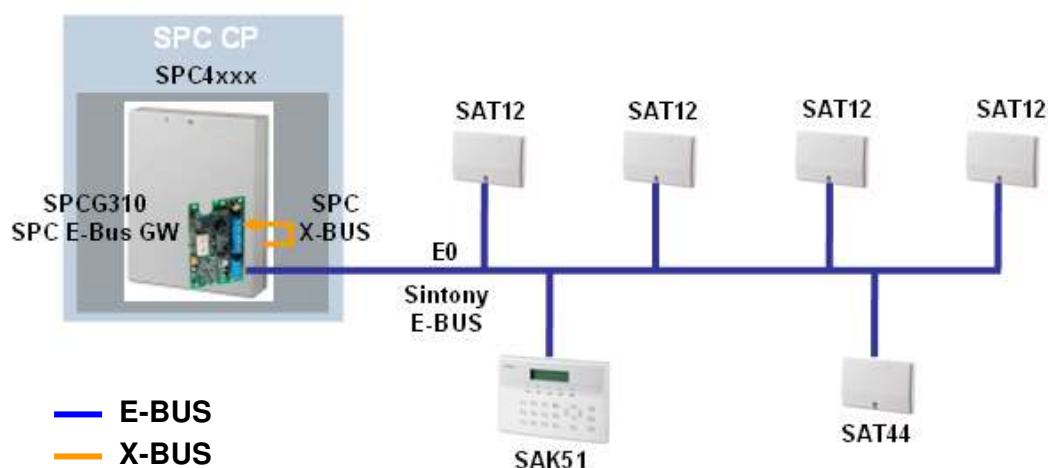

In the above diagram the SPC E-Bus GW (SPCG310) is shown mounted in the SPC control panel housing. It can also be mounted in Sintony SAH14 housing or in external power supply housing.

Simulated Migration

Following migration the “Small Installation” appears to the SPC controller as a simulated SPC installation. The physical Sintony peripheral devices remain unchanged i.e. physically the peripheral devices are Sintony devices but the SPC controller sees equivalent simulated SPC devices on a simulated X-BUS network.

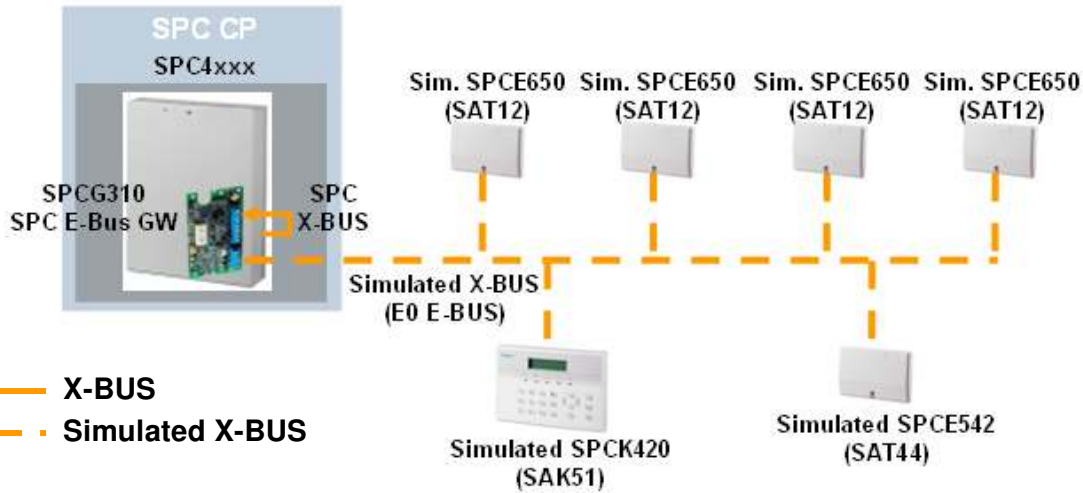

Note: Simulated X-BUS = Physical E-Bus which has been simulated and appears to the SPC controller as X-BUS

The spur (or open loop) cabling method is used in this example. The SPC4xxx control panel does not support closed loop cabling topology.

Note: Sintony to SPC migration does not support Star and Multi-drop cabling methods

The cable map of this Sintony to SPC migration example can be as follows:

Alarms disabled full engineer mode						
Status	System	Controller	X-BUS	Comms.	Verification	Advanced
Keypads Expanders Door Controllers Cable Map Settings						
X-BUS Cable Map						
Position	ID	Status	Type	S/N	Description	
1	99	Active	Gateway	5020700	GW 99	
2	1	Active	I/O [8 Input / 2 Output]	5020701	IO 1	
3	81	Active	Keypad	5020781	KEY 81	
4	2	Active	I/O [8 Input / 2 Output]	5020702	IO 2	
5	3	Active	I/O [8 Input / 2 Output]	5020703	IO 3	
6	71	Active	I/O [8 Output]	5020771	IO 71	
7	4	Active	I/O [8 Input / 2 Output]	5020704	IO 4	

Reconfigure

Example 2: Medium Installation

The following is an example of a medium Sintony installation, consisting of:

- 1 X SI220 Sintony Control Panel
- 1 X E-Bus (E0)
- 3 X SAT12; 2 X SAT44; 2 X SAK51; 1 X SAP14

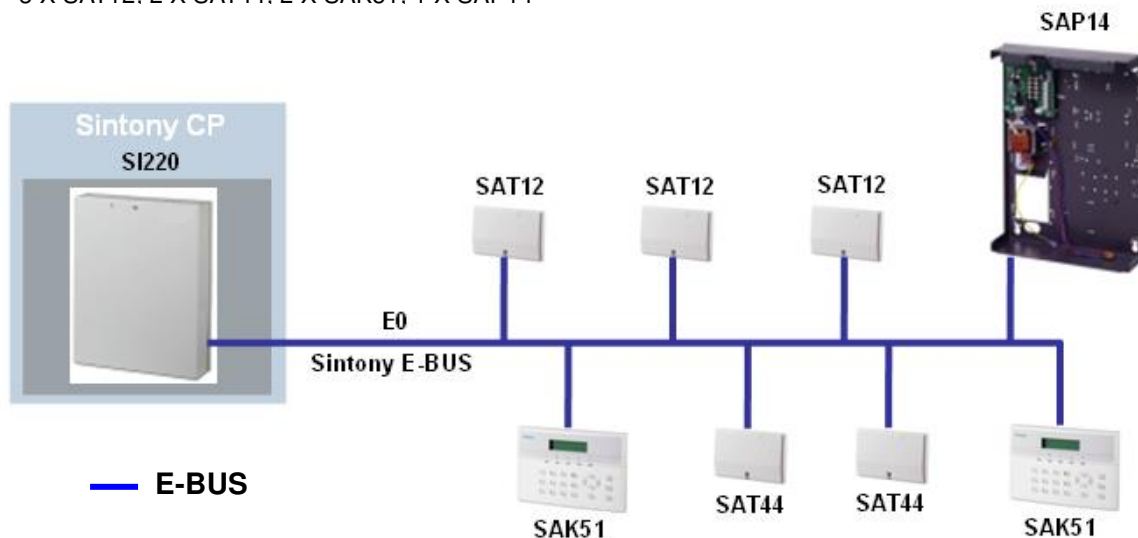

Physical Migration

The existing Sintony CP SI220 is replaced with a new SPC5xxx control panel. The Sintony E-Bus (E0) is disconnected when the SI220 control panel is removed. A new SPC E-Bus GW (SPCG310) is added to the system. The Sintony E-Bus (E0) is re-wired to the E-Bus terminals of the newly added SPC E-Bus GW and the SPC X-BUS is wired to the X-Bus terminals of the SPC E-Bus GW (as per normal SPC X-Bus peripheral devices).

In this “Medium Installation” example for physical migration the system has been expanded with SPC peripheral devices in order to demonstrate how an existing Sintony system can be expanded with SPC peripheral devices. The SPC peripheral devices added are 1 X SPCK420, 1 X SPCE452 and 1 X SPCE652.

Note: The X-BUS of this SPC5xxx system installation is wired using the closed loop cabling method.

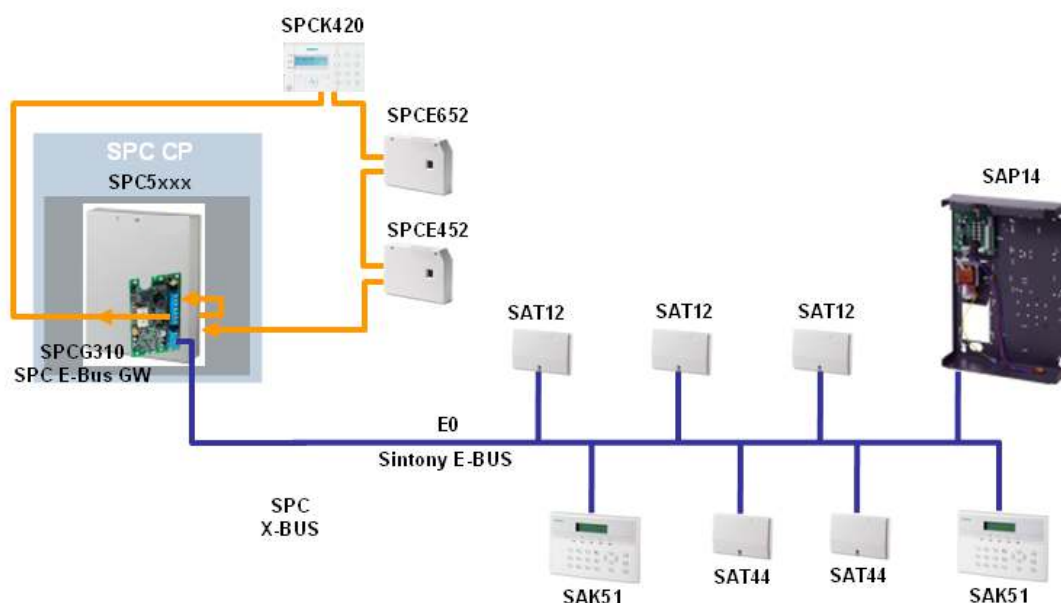

Simulated Migration

Following migration this “Medium Installation” appears to the SPC controller as an SPC installation made up of a physical SPC X-BUS and a simulated SPC X-BUS (physical Sintony E-Bus) wired in a closed loop topology.

Physically it is not possible to wire Sintony E-Bus devices in a closed loop. However, for migration all physical Sintony peripheral devices are mapped to simulated SPC peripheral devices and recognized by the SPC controller as SPC X-Bus devices. In this “Medium Installation” the physical E-Bus devices simulated as SPC X-Bus devices are identified as being wired in a closed loop.

The cable map of this Sintony to SPC migration example can be as follows:

Alarms disabled full engineer mode							
Status	System	Controller	X-BUS	Comms.	Verification	Advanced	Test Menu
Keypads Expanders Door Controllers Cable Map Settings							
X-BUS Cable Map							
Position	ID	Status	Type	S/N	Description		
1	99	Active	Gateway	5020700	GW 99		
2	1	Active	I/O [8 Input / 2 Output]	5020701	IO 1		
3	81	Active	Keypad	5020781	KEY 81		
4	2	Active	I/O [8 Input / 2 Output]	5020702	IO 2		
5	71	Active	I/O [8 Output]	5020771	IO 71		
6	3	Active	I/O [8 Input / 2 Output]	5020703	IO 3		
7	72	Active	I/O [8 Output]	5020772	IO 72		
8	5	Active	I/O [8 Input / 2 Output]	5020705	IO 5		
9	82	Active	Keypad	5020782	KEY 82		
10	4	Active	Keypad	105862801	KEY 1		
11	6	Active	I/O [8 Input / 2 Output]	102117801	IO 6		
12	7	Active	I/O [8 Output]	102190801	IO 7		
Reconfigure							

Example 3: Large Installation

The following is an example of a large Sintony installation, consisting of:

- 1 X SI410 Sintony Control Panel
- 2 X E-Bus (E0, E1)
- 1 X SAG91
- 6 X SAT12; 2 X SAT44; 3 X SAK51; 1 X SAP25

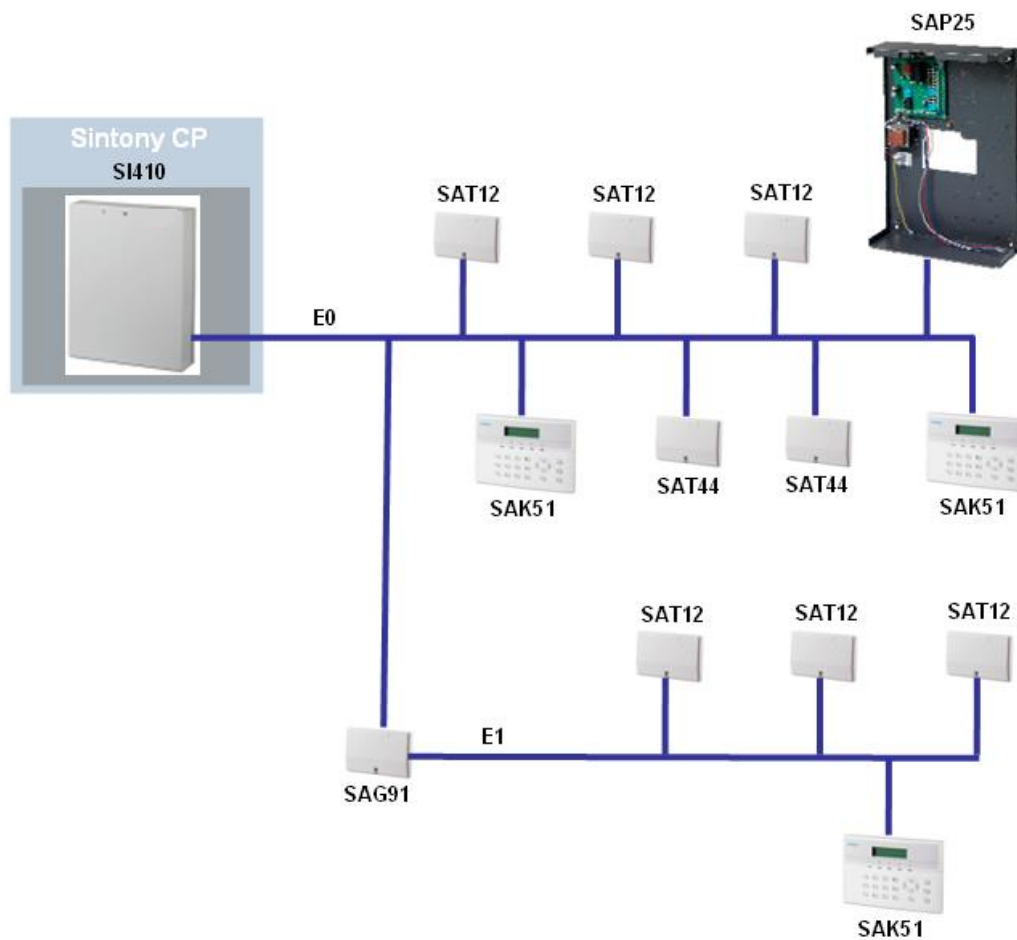

Note: In reality a large installation would be a lot more populated. This example just highlights common large installation components.

Physical Migration

The existing Sintony CP SI410 is replaced with a new SPC6xxx control panel. The Sintony E-Bus (E0) is disconnected when the SI410 control panel is removed. A new SPC E-Bus GW (SPCG310) is added to the system. The Sintony E-Bus (E0) is re-wired to the E-Bus terminals of the newly added SPC E-Bus GW and the SPC X-BUS is wired to the X-Bus terminals of the SPC E-Bus GW (as per normal SPC X-Bus peripheral devices).

A second SPC E-Bus GW is added to the system in order to support E-Bus E1. In this case the existing SAG91 is replaced with a new SPC E-Bus GW.

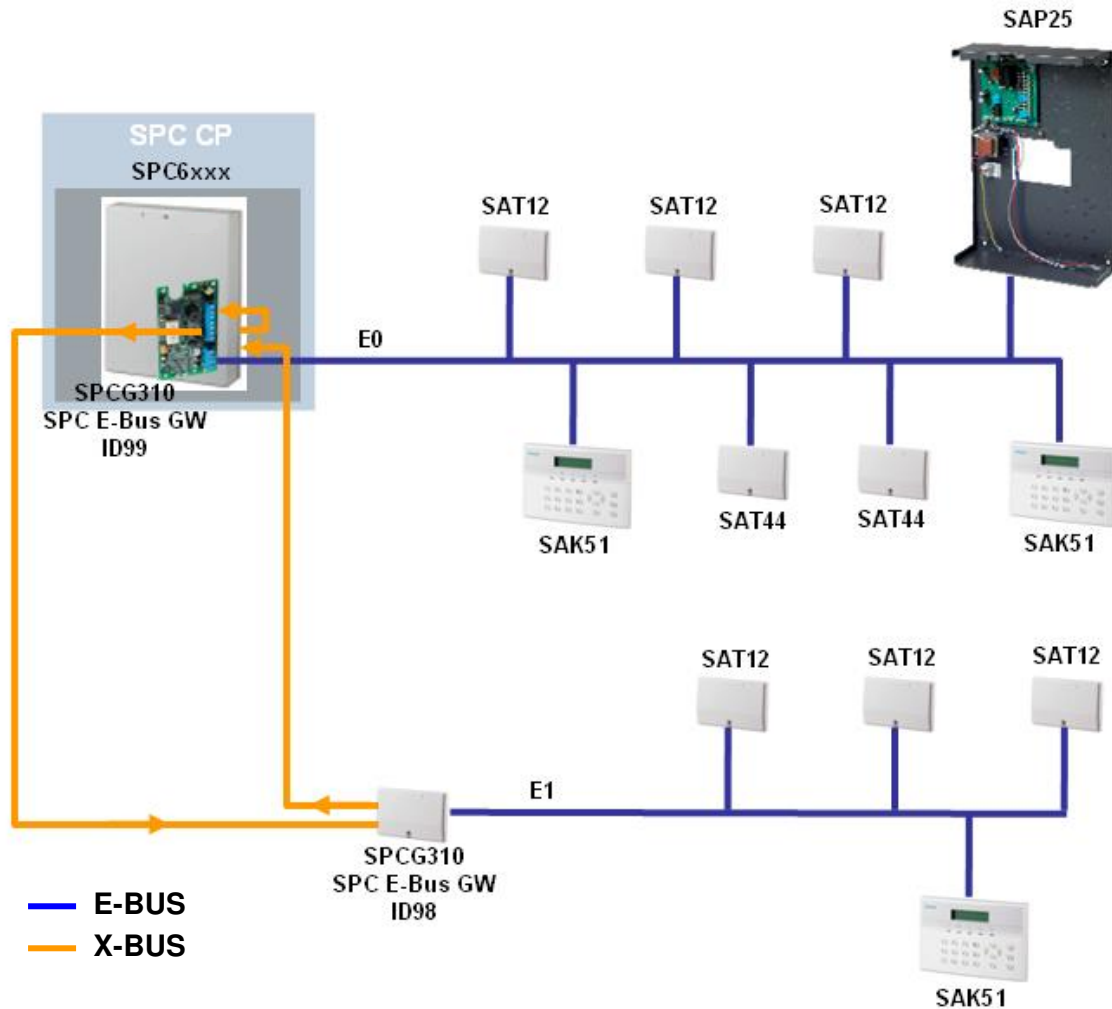

Simulated Migration

Following migration this “Large Installation” appears to the SPC controller as a single simulated SPC X-BUS installation wired in a closed loop topology.

Note: Ensure that all peripheral device addressing and system setup steps are followed as outlined previously.

The cable map of this Sintony to SPC migration example can be as follows:

Alarms disabled full engineer mode							
Status	System	Controller	X-BUS	Comms.	Verification	Advanced	Test Menu
Keypads Expanders Door Controllers Cable Map Settings							
X-BUS Cable Map							
Position	ID	Status	Type	S/N	Description		
1	99	Active	Gateway	5020700	GW 99		
2	1	Active	I/O [8 Input / 2 Output]	5020701	IO 1		
3	81	Active	Keypad	5020781	KEY 81		
4	2	Active	I/O [8 Input / 2 Output]	5020702	IO 2		
5	71	Active	I/O [8 Output]	5020771	IO 71		
6	3	Active	I/O [8 Input / 2 Output]	5020703	IO 3		
7	72	Active	I/O [8 Output]	5020772	IO 72		
8	5	Active	I/O [8 Input / 2 Output]	5020705	IO 5		
9	6	Active	I/O [8 Input / 2 Output]	5020706	IO 6		
10	82	Active	Keypad	5020782	KEY 82		
11	98	Active	Gateway	5021500	GW 98		
12	7	Active	I/O [8 Input / 2 Output]	5021507	IO 7		
13	8	Active	I/O [8 Input / 2 Output]	5021508	IO 8		
14	83	Active	Keypad	5021583	KEY 83		
15	9	Active	I/O [8 Input / 2 Output]	5021509	IO 9		

Reconfigure

Issued by
Vanderbilt International (IRL) Ltd.
Clonshaugh Business and Technology Park
Clonshaugh
Dublin 17
Ireland

www.vanderbiltindustries.com

All rights reserved. All trademarks used
are owned by Vanderbilt or their respective owners.

© Copyright Vanderbilt 2016

Technical specifications and availability subject to change
without notice.